



Assumptions for Connecticut Analysis Reference Case

Prepared by:

ICF Consulting

October 30, 2003

Outline

- Project Overview
- Analytic Approach
- Regulatory Assumptions
- Run Year Structure
- Technical and Market Assumptions Overview
- NEPOOL Regional Transmission Assumptions
- General Assumptions
 - Macroeconomic and Power Market Drivers
 - Coal Prices, Gas Prices, and Variable O&M
 - New Power Plants
 - Nuclear Technologies
 - Coal and Gas Technologies
 - Renewable/Advanced Technologies
 - Planned Capacity Additions for NEPOOL
- Emissions Control Assumptions

Project Overview

Introduction and Goals of the Analysis

- ICF has been commissioned to analyze the impact of a number of potential emissions, renewable, energy efficiency and other policies on the electric generation sector in Connecticut and surrounding regions.
- The analysis will provide a broad assessment of the range of potential impacts of policy design alternatives on the state and regional markets.
- ICF's proprietary modeling system, IPM[®], will be used to estimate these impacts on power, fuel, and emission market dynamics.

Adoption of Approved Assumptions by the Connecticut GHG Stakeholder Dialog

- Numerous assumptions are required to perform an analysis of this type. The purpose of this document is to present those assumptions that have been adopted by the Working Group and/or Stakeholders for use in this analysis.
- All assumptions in this document have been approved and adopted by the study participants. These assumptions are the sole responsibility of the Connecticut GHG Stakeholder Dialog.

Analytic Approach

IPM[®] Analytic Framework

IPM[®] Modeling Structure



The IPM[®] Modeling Framework

- The Integrated Planning Model (IPM[®]) has been used to analyze the impacts of environmental policies on allowance markets, fuel markets, electric markets and compliance decisions.
- IPM[®] is a linear programming model with a detailed representation of every boiler and generator operating in the United States. The model determines the least cost means of meeting electric energy and capacity requirements, while complying with air regulations and renewable portfolio standards.
- In addition to optimizing wholesale and environmental markets, IPM[®] simultaneously optimizes coal production, transportation and consumption.
 - IPM[®] contains 40 coal producing regions and has over 10 coal types defined by sulfur and mercury content.
 - Each coal plant is assigned to one of over 40 coal demand regions characterized by location and mode of delivery including rail, barge, and truck.
- Natural gas prices are derived within IPM[®] using a similar supply curve and transportation network.

IPM[®] Regional Map*

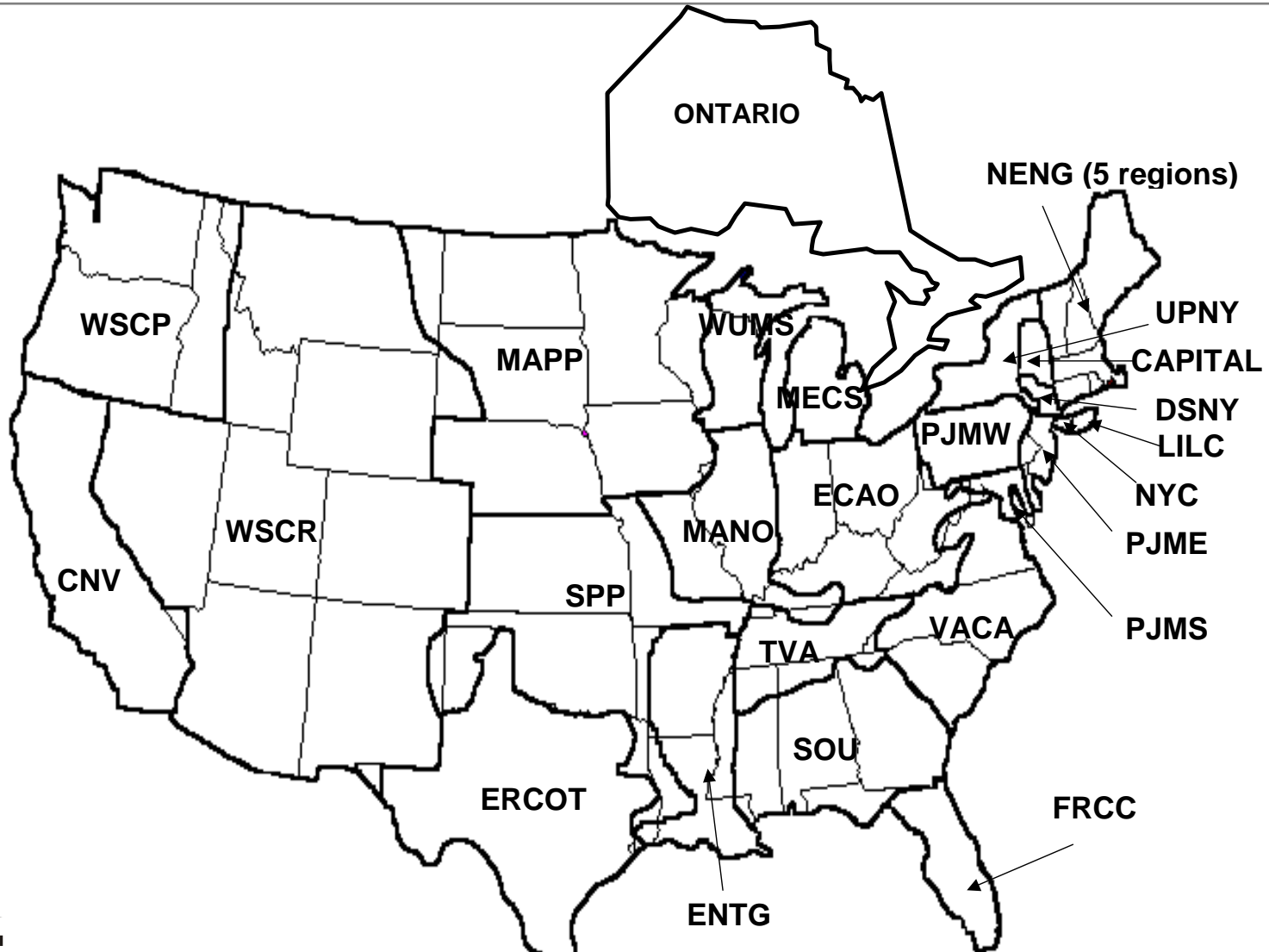

IPM[®] Model Regions

- National IPM[®] divides the United States into regions, closely resembling NERC regions. ICF divides further NERC regions based on known transmission bottlenecks (i.e. sub-regions in which spot prices are expected to diverge significantly), or when clients request specific regional breakouts.
- For the purpose of this analysis, National IPM[®] will be disaggregated into 28 regions, including Ontario and 7 New England regions. The New England regions, shown in greater detail in the Transmission section of this document, are:
 - Maine
 - NEPOOL-East
 - SEMA/RI
 - Norwalk, CT
 - Southwest CT
 - Other CT
 - West Central MA and VT
- All IPM[®] regions have a representation of the electric transmission system that connects neighboring regions. The inter-regional transmission connections allow for the transfer of both capacity and energy and allow for broad price equilibration when transmission capacity is available.

IPM[®] Coal Supply Regions

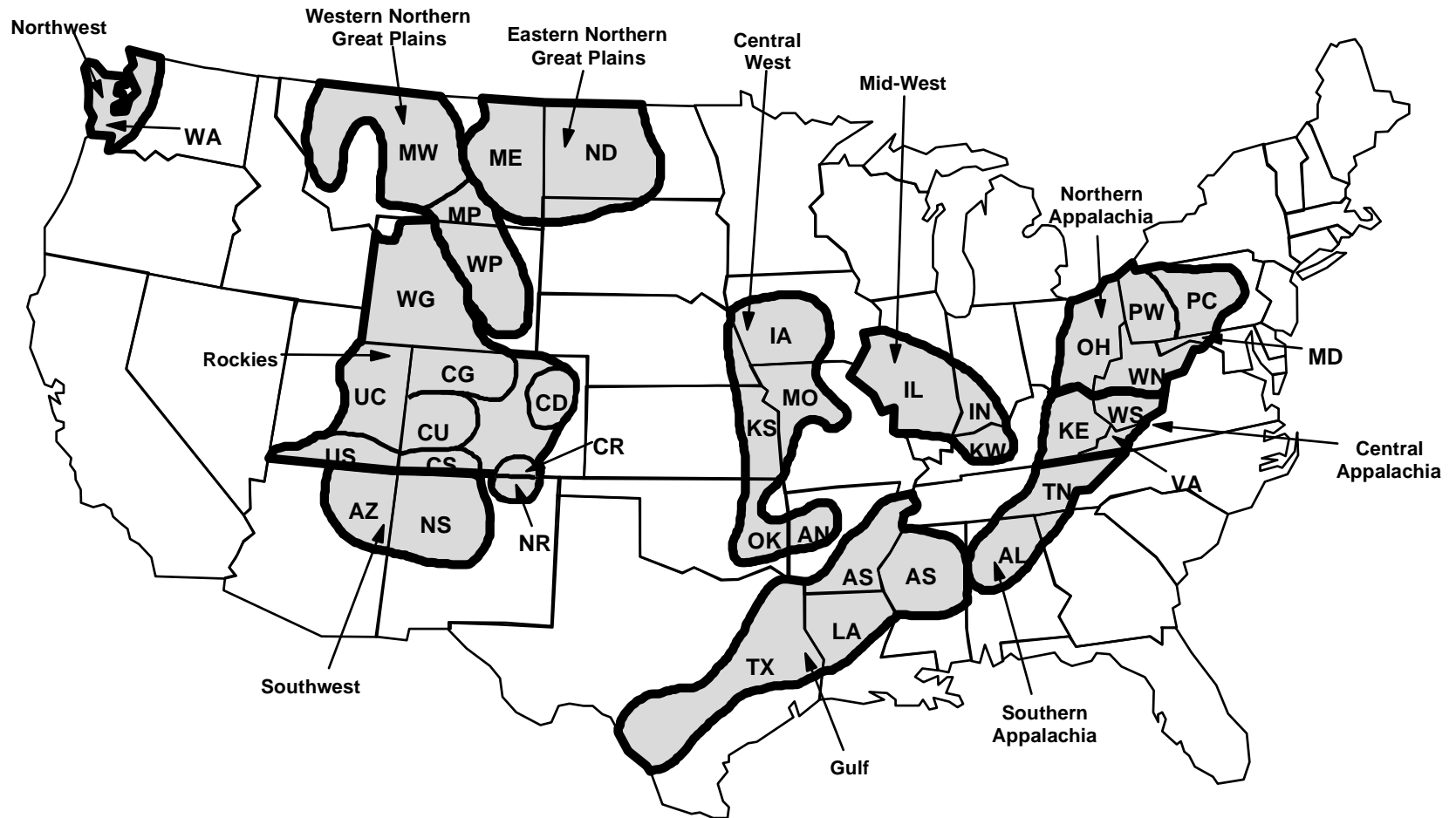

Representation of Coal Supply, Demand, and Transportation in IPM[®]

- IPM[®] forecasts coal production from over 40 supply regions:
 - Bituminous, sub-bituminous, lignite
 - 12 different sulfur grades
 - Multiple mercury contents
- Each coal power plant is assigned to one of 41 coal demand regions based on location and mode of delivery.
- Coal transportation network links coal supply and demand regions.
- Coal consumption by sulfur grade is a function of electricity generation levels, air pollution regulations, and oil and gas prices.

IPM[®] Layers Rich Detail of Renewable Supply and Demand into the Broader Power Market Specification

Demand

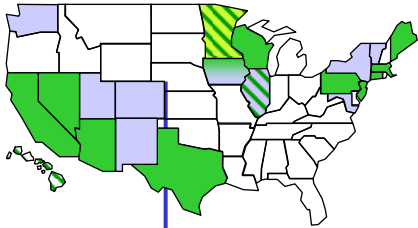

State patchwork of RPSs and retail green demand; national RPS policy

Specify trading rules and allowable generation types

Supply

Cost and performance of new renewable generation capacity; renewable tax policy

Resource constraints: wind availability by region, geothermal sites, solar and landfill resources

Database of existing renewable generators

IPM[®] Modeling Structure

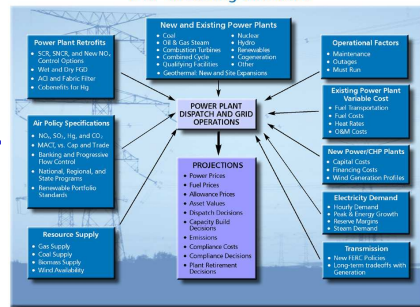

- Renewable energy credit values are determined by the *demand* for green power and the characteristics of sources available to *supply* that demand.
- The demand for green power will consist of a grassroots component – the generation required to satisfy consumer interest in non-emitting electric power – and a mandated component – the generation required to comply with renewable portfolio standards. Grassroots demand is only included for those states without an RPS.
- The total demand will be met by existing and new renewable generators specified by cost, performance, and resource availability.
- IPM[®] brings together these essential components of renewable power development in a single integrated structure to determine market equilibrium conditions within the broader context of the electric, fuel, and environmental markets.

Regulatory Assumptions

Reference Case Regulatory Specification

- The purpose of a Reference Case is twofold: 1) to understand system operations and compliance under existing regulations and 2) to establish points of comparison for policy analysis.
- In its most basic form, this scenario should include current regulations as well as those regulations that are reasonably certain to be implemented in the future.
 - The Stakeholders have agreed to model a 3-pollutant policy in the Reference Case, in addition to current Title IV SO₂ regulations, the NO_x SIP Call and state specific air regulations, such as those in Connecticut, Massachusetts, New Hampshire, and New York.
- The following slides show the specifications for the NO_x SIP Call, state regulations, and 3-P regulation.

NO_x SIP Call Market Coverage

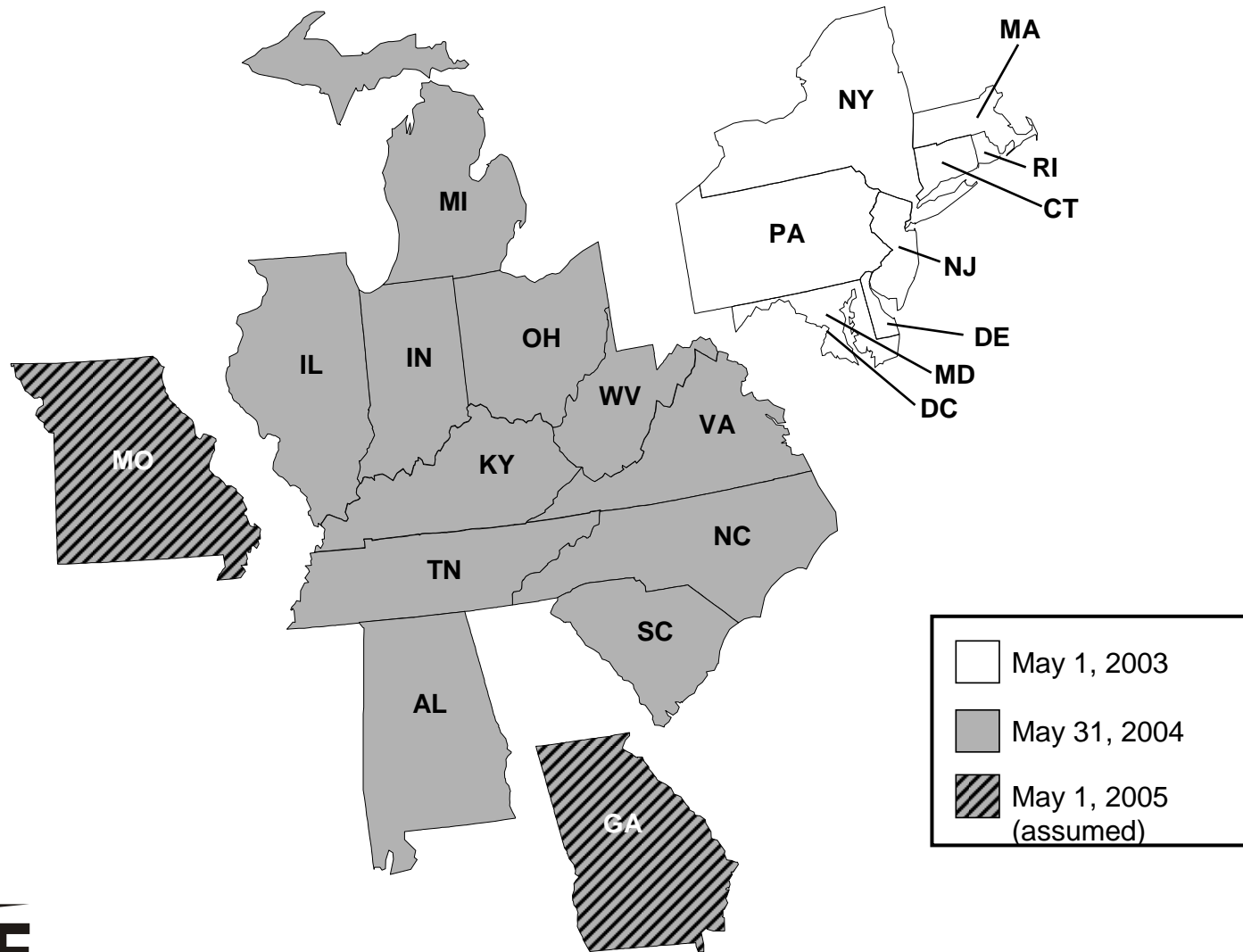

State Specific Air Regulations

State	Notes	Status	NO _x	SO ₂	Mercury	Carbon
Connecticut	Trading or Facility Specific	Promulgated on 12/28/2000	Non-Ozone Cap @ 0.15 lb/MMBtu in '02 (Trading)	0.55 lb/MMBtu in '02 0.33 lb/MMBtu in '03 (Facility)	0.6lb/Tbtu or 90% from input, whichever least stringent in '08 (Facility)	NA
Massachusetts	All policies are facility specific (i.e. No trading)	Promulgated on 5/11/2001	1.5 lb/MW/hr by '04	6 lb/MW/hr by '06 3 lb/MW/hr by '08	85% from input by 10/1/2006; 95% from input by 10/1/2012	Facility level by '06; 1800 lb/MW/hr by '08
New Hampshire	Trading and Banking Allowed	Passed House Committee on 11/28/2001	Annual Cap @ 1.5 lb/MW/hr in '06 3,644 tons	Annual Cap @ 3.0 lb/MW/hr in '06 7,289 tons	Cap level by '04 for policy in '06	5.426 million tons in '06 to '10; Phase II cap TBD
New York	Trading and Banking Allowed	Passed 3/26/2003	Non-Ozone Cap @ 0.15 lb/MMBtu in '04 3:1 IP* 39,908 tons	25% below Phase II in '05 50% below starting '08 3:1 IP*	NA	under development
Wisconsin	Standards for 8 WEPCO facilities	Environmental Cooperative Agreement	Annual Cap @ 0.25 lb/MMBtu in '08 0.15 lb/MMBtu in '13	Annual Cap @ 0.7 lb/MMBtu in '08 0.45 lb/MMBtu in '13	10% off '99 levels in '08 50% off '99 levels in '13	NA
North Carolina	In-State Trading Only	Signed into law on June 20, 2002	56,000 Ton NO _x cap (78% Reduction) by 2009	250,000 Ton SO ₂ cap (49% Reduction) by 2009	NA	NA

*IP=Import Penalty—ratio of upwind tons redeemed for a single in-state ton.

**Houston Cap phased in over time starting in 2002.

***2/3 of Dallas reductions must be achieved by 2003.

Multi-Pollutant Policy in Reference Case

	Policy Stringency & Timing				Key Provisions
	Annual NO _x (million tons)	Annual SO ₂ (million tons)	Annual Hg (tons)	Annual CO ₂ (million tons)	
<i>Representative 3-P Regulation</i>	2.1 in 2008 1.7 in 2018	4.5 in 2010 3.0 in 2018	26 in 2010 15 in 2018	N/A	•East/West NO _x Trading Zones

- A multi-pollutant policy is included in the Reference Case as a proxy for either:
 - Continued implementation of the Clear Air Act Amendments requiring a Mercury MACT and PM_{2.5} standards (which would likely require reductions in the SO₂ cap and the implementation of a national NO_x cap.)
 - The passage of a multi-pollutant bill in Congress.
- The policy highlighted above was chosen for being representative of these measures.

RPS Policy Implementation in the Northeast

- The Stakeholders have chosen to include existing and planned RPS programs in the Reference Case. The table on the following slide shows the specific requirements of the RPS programs that the Working Group has chosen to model in the Reference Case.
 - The “Qualifying Capacity” entries include only those technologies that will be represented as options in the analysis. Some capacities that do qualify, such as tidal energy, will not be examined within IPM.
- The Stakeholders have chosen to allow the Northeast RPS programs shown (CT, MA, NY, PA, NJ) to be complied with using tradable renewable energy credits (RECs) created from resources generating in any of the participating systems, including PJM, NEPOOL and NYISO.
 - Within IPM®, this design measure will effectively result in a single market for RECs across the entire Northeast, with the demand for RECs being set by the sum of the requirements in all of the participating regions.
 - As a result, a single REC price will be reported for the entire region.

Summary of Northeast RPS Policies

Regional Market	State	Standard in 2005 and Later	Capacity Types
NEPOOL / New York / PJM	Connecticut (Class I)	1.5% in 2005 growing to 7% in 2010 and later	Wind, Landfill Gas, Biomass Gasification, Fuel Cells, Solar PV, Hydro (smaller than 5 MW)
	Massachusetts	2% in 2005 growing to 4% in 2009, plus 1% growth/year thereafter	Wind, Landfill Gas, Biomass Gasification, Fuel Cells, Solar PV, Hydro (smaller than 5 MW)
	New York	1% incremental in 2006 growing to 8% incremental in 2013	Wind, Landfill Gas, Biomass Gasification, Fuel Cells, Solar PV, Hydro (smaller than 5 MW)
	New Jersey (Class I)	0.75% in 2005, 1.0% in 2006, 4% in 2012 and later	Wind, Landfill Gas, Biomass Gasification, Fuel Cells, Solar PV, Hydro (smaller than 5 MW)
	Pennsylvania	2% in 2001; increasing 0.5% annually, but only for PECO	Wind, Landfill Gas, Biomass Gasification, Fuel Cells, Solar PV, Hydro (smaller than 5 MW)

Run Year Structure

IPM[®] Generates Results for Specific Run Years

- Because of the level of detail represented within the national model, IPM[®] is limited to generating results for 5 *run years*.
 - A run year is a calendar year chosen to represent a single year or a group of years that face similar electric and fuel markets and environmental policies.
- To understand the mid- to long-term impacts of the policies being examined here, the Stakeholders have agreed to the following run year structure for this analysis. This structure will be held constant throughout all runs once the Reference Case modeling begins.
 - Note that this run-year structure does not lend itself to an updating allocation mechanism in any future policy runs.

Calendar Year	Run Year
2005	2006
2006	
2007	
2008	2008
2009	
2010	2010
2011	
2012	
2013	2015
2014	
2015	
2016	
2017	
2018	2020
2019	
2020	
2021	
2022	

Technical and Market Assumptions Overview

Technical and Market Assumptions Overview

Item	Source
CT, NEPOOL and National Load and Peak Demand Forecast	New England: ISO-NE 2003 Forecast, 2005-2012 growth; EIA 2013-2022 growth Other Regions: EIA
Reserve Margin Assumptions	ICF
Financing for Capital Projects – new builds and retrofits	ICF
Coal supply, minemouth and transportation prices	ICF w/ Working Group input on international coal
Natural Gas Prices	EIA

Item	Source
Greenfield Cost and Performance Characteristics of Conventional (fossil) Generation	EIA
New Build Emissions Profiles	ICF
Firm (Hardwired) Builds	ISO New England for NEPOOL, ICF for other
Greenfield Cost and Performance Characteristics of Renewable Generation	NREL, EIA, EPA
Emissions and Control Assumptions	EPA

NEPOOL Regional Transmission Assumptions

7 NEPOOL Regions to be Modeled in IPM[®]

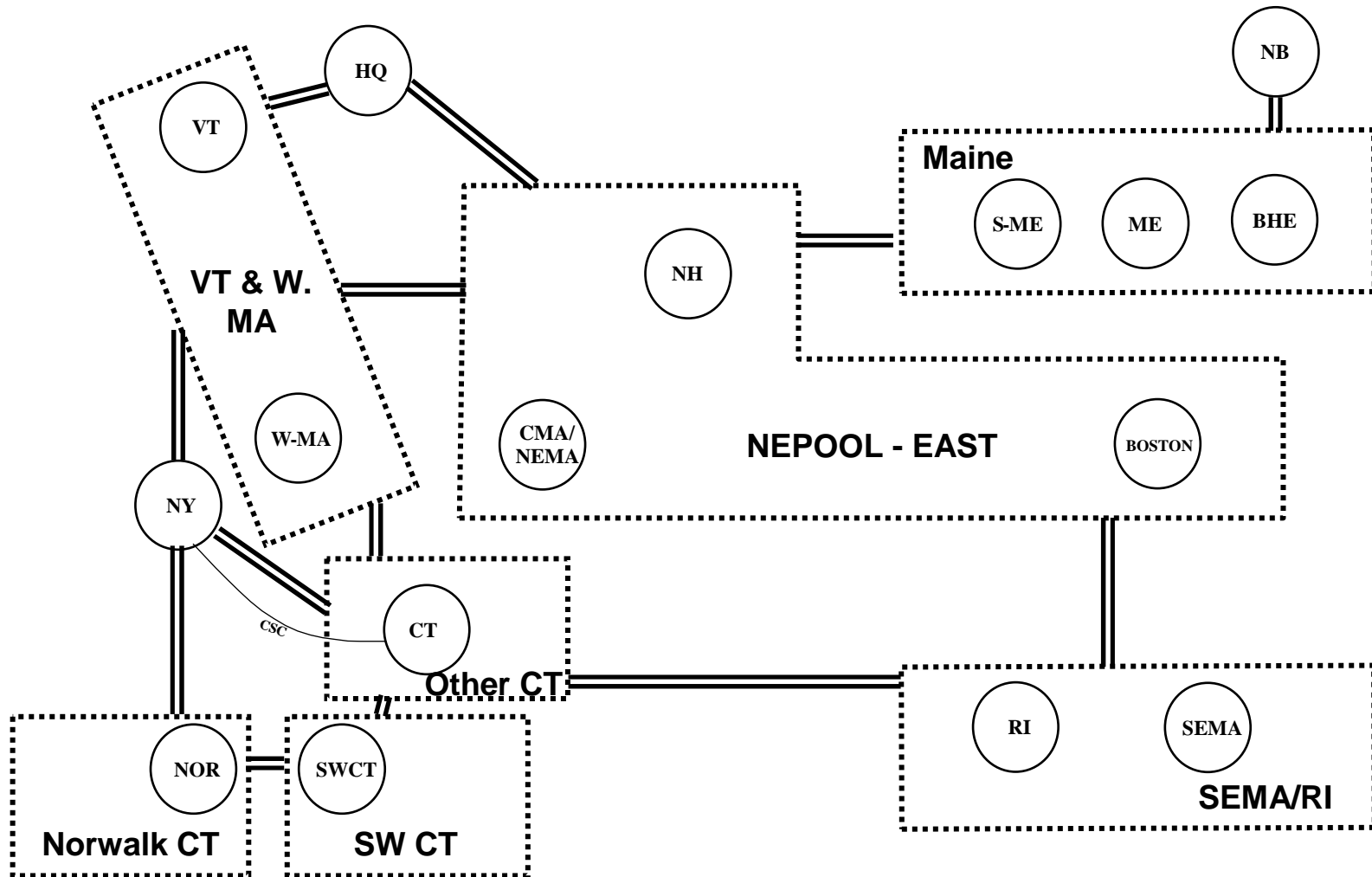

7 NEPOOL Regions to be Modeled in IPM[®] cont.

- The zones represented in the previous slide will be aggregated within IPM[®] into 7 NEPOOL sub-regions as reflected by the dashed lines shown in the figure:
 - NEPOOL-East
 - Norwalk, CT
 - Southwest CT
 - Other CT
 - West Central MA and VT
 - Maine
 - Southeast MA and Rhode Island
- Model results will be presented for each of those regions.
- The transmission links modeled will include those connecting aggregate sub-regions.
- Note that IPM represents a fixed total transfer capability (TTC) for each link over the course of a year and does not account for hourly variations in the actual capability of the lines. TTCs are shown on the following page and were developed by ICF based on information from the 2003 Regional Transmission Expansion Plan (RTEP03) and other sources.

NEPOOL Transmission Total Transfer Capabilities Among the 7 Regions in IPM®

NEPOOL Transmission Properties		
From	To	Transmission Capability (MW)
Connecticut	LILCO AC (NY)	100
Connecticut	LILCO DC (NY)	330
Connecticut	SEMA/RI	2,030
Connecticut	New York	1,000
Connecticut	Southwest Connecticut	2,600 / 3,400*
Connecticut	Vermont/Western Massachusetts	2,030
Connecticut - Norwalk	New York	1,000
Connecticut - Norwalk	Southwest Connecticut	670
LILCO AC (NY)	Connecticut	100
LILCO DC (NY)	Connecticut	330
Maine	NEPOOL-East	1,400
NEPOOL-East	Maine	1,400
NEPOOL-East	SEMA/RI	5,850
NEPOOL-East	Vermont/Western Massachusetts	2,100
New York	Connecticut	1,400
New York	Connecticut - Norwalk	1,100
New York	Vermont/Western Massachusetts	1,400
SEMA/RI	Connecticut	2,100
SEMA/RI	NEPOOL-East	5,850
Southwest Connecticut	Connecticut	1,850
Southwest Connecticut	Connecticut - Norwalk	1,300 / 1,500*
Vermont/Western Massachusetts	Connecticut	2,500
Vermont/Western Massachusetts	NEPOOL-East	2,100
Vermont/Western Massachusetts	New York	1,000

* Values reflect implementation of Phase I (2005) and then Phase II (2008) capability expansions.

Joint Transfer Capacity Limits

- Constraints can be applied to transfer capabilities over multiple lines such that the total transmission into or out of a region is limited to an amount less than the sum of all of the transfer capability linked to the region.

- While RTEP03 provides both Summer and Winter values for some constraints, they will be represented in IPM on an annual basis. Where appropriate, the Electricity Working Group has chosen to use the Summer values from RTEP03 (Appendix Table 1.2) to simulate the constraints for the peak Summer season. The following constraints apply across NEPOOL:
 - NEPOOL to NYPP has a joint capability limit of 950 MW
 - NYPP to NEPOOL has a joint capability limit of 1,550 MW
 - Southwest CT has a joint import capability limit of 2,600 MW in 2005 and 3,400 MW in 2008
 - Norwalk-Stamford has a joint capability limit of 1,300 MW in 2005 and 1,500 MW in 2008
 - SEMA/RI has a joint export capability limit of 3,000 MW
 - East (NEPOOL-East and SEMA/RI) has a joint capability limit to West (VT and W. Mass and CT regions) of 2,400 MW
 - CT has a joint import capability limit of 2,200 MW

General Assumptions

Macroeconomic and Power Market Drivers

Load Projections for New England

- The ISO-NE 2003 forecast load for each of those regions is presented below.
- The Working Group has decided to use ISO-NE's load growth projections for New England. These projections are available through 2012. For years beyond 2012, ISO-NE has suggested using EIA's growth rates. The table below shows the combination of the two sources.
 - EIA growth rate assumptions will be used for all other regions being modeled.

Net Energy for Load (GWh)	Forecast 2003	% Growth per Year: ISO-NE (through 2012), EIA (2012 and later)			
		2005 - 2012	2013 - 2015	2015 - 2020	2005 - 2020
NEPOOL-East	43,181	1.50%	0.97%	0.91%	1.15%
Maine	11,277				
SEMA/RI	23,379				
Norwalk, CT	5,862				
Southwest CT	10,944				
Other CT	16,760				
West Central MA and VT	17,567				
Total New England	128,970				

Reserve Margins Drop Over Time

- ICF models reserve margin requirements in order to capture ongoing reliability standards. These reserve margins require the model to build economic capacity additions to meet peak demand plus a specified percentage in each model region.
- The reserve margin as represented within the IPM structure represents a floor, and not a forecast of the actual level.
- Historically, reserve margins have been declining as more inter-regional power transfers and increasing real-time response options have reduced the need for dedicated reserve capacity.
- Each model region has a specific trajectory of projected reserve margin requirements. These assumptions are based on a number of sources, primarily NERC projections and regional reliability council estimates.

Reserve Margin (%)	2005-2007	2008-2009	2010	2011+
All Regions in NEPOOL	17%	15%	14%	13%

Demand Response for Policy Scenarios

- Characteristics in the policy and technical scenarios may result in a significant change in electric prices relative to the Reference Case results.
 - Carbon policies, especially, can drive up power prices well above Reference Case levels.
- Consumers are likely to respond to higher power prices by reducing their demand. In IPM, this effect is captured through a demand response mechanism.
- The Stakeholders have approved the use of demand response in the policy and technical scenarios.
 - Price movement in the policy and technical scenarios is measured relative to the Reference Case, so the Reference Case does not include demand response.
- Demand response is defined as the percent change in energy consumed given a 1% change in price.
- The Working Group has decided to use a weighted average demand response value calculated based on:
 - The lower end of demand response assumed by EIA in its analysis of the Kyoto Protocol for the residential sector,
 - Commercial and industrial sector response specified as EIA's commercial sector assumption in its Kyoto Protocol analysis, and
 - Sector weighting by end-use demand based on actual 2000 electricity consumption.
- Based on that methodology, the demand response in this analysis will range from -0.30 in the near-term (2005) to -0.35 in the long-term (2020). Demand response will be interpolated between 2005 and 2020.
 - Note that the demand response values provided characterize response at the retail price level. Because IPM[®] operates at the wholesale level, these response values will be adjusted to reflect the portion of delivered retail energy prices accounted for by wholesale prices (roughly 30%).

**Coal Prices, Gas Prices, Oil Prices, and
Variable O&M**

Coal

Coal Mining Productivity Improvements Will Slow Over Time

- The Current ICF Reference Case forecast assumes a gradual decrease in the the rate of productivity improvements over time. Productivity assumptions are based on DOE/EIA Annual Energy Outlook (AEO) 2002 projections.
- Productivity improvements have historically been higher in the west. The Reference Case forecast assumes that historical regional variations in productivity improvement will continue. While PRB productivity is expected to experience continued growth, dramatic increases in PRB demand offset these improvements, leading to a stable minemouth price over time.
- The rate of mining productivity improvement is expected to slow as long-wall mining applications are exhausted. Other major breakthroughs in mining technology are not expected in the near-term.
- Limited data is available on the price and environmental characteristics of imported coal. A June 2000 presentation to the 1st U.S. International Coal Conference contained the following data (all price delivered to plant; based on 1999 coal imports):
 - Colombia: \$1.50/MMBtu with 1.02 lbs. SO₂/MMBtu
 - Venezuela: \$1.50/MMBtu with 1.09 lbs. SO₂/MMBtu
 - Indonesia: \$1.36/MMBtu with 0.30 lbs. SO₂/MMBtu
- Mercury contents of these coals are not available.

ICF Coal Productivity Annual Growth Rate Assumptions (%)

Year Range	Appalachian Region	Internal Region	Western Region
1995-2000	4.3	3.2	4.6
2001-2005	2.4	1.7	2.5
2006-2010	1.9	1.4	2.0
2011-2030	1.0	0.7	1.1

Coal Transportation Costs

- Current ICF Assumptions for Transportation Costs assumes a constant 2 percent annual decrease in the cost of transportation.
- Transportation costs from PRB supply regions to central and eastern coal demand regions contain a cost adder to approximate capital costs associated with switching to lower sulfur coals that is roughly equivalent to a \$50/kW.

Gas

EIA AEO 2003 Average Lower 48 Wellhead and Gulf Coast Wellhead Forecast (Year 2000 \$/MMBtu)

- Delivered gas prices to regions in IPM[®] consist of commodity (wellhead) prices determined by the national demand for gas, transportation costs (basis differentials), and seasonal cost adjustments.
 - Basis differentials and seasonal cost adjustments, shown on the following slide, remain fixed in the analysis.
- The Reference Case Henry Hub wellhead gas price trajectory will be used as a basis for developing national natural gas supply curves.
 - This curve structure will capture within IPM[®] shifts in the commodity price resulting from changes to the supply and demand of gas brought about by environmental regulation.
- The Stakeholders have agreed to use EIA's AEO 2003 gas price trajectory in the Reference Case. The Lower 48 average is conventionally used to discuss EIA price trajectories. EIA's corresponding Gulf Coast projection is also shown. IPM is indexed off of the Henry Hub price based on that projection.

(Year 2000 \$/MMBtu)	Lower 48 Average	Gulf Coast	Henry Hub*
2005	2.73	2.79	2.86
2010	3.12	3.10	3.17
2015	3.37	3.44	3.51
2020	3.50	3.61	3.68
2025	3.70	3.92	3.99

* EIA Henry Hub price estimated based on Gulf Coast projection from AEO2003 with a \$0.07/MMBtu adder.

ICF Regional Delivered Regional Basis Differentials and Delivered Gas Price Seasonality (Year 2000 \$/MMBtu)

IPM Region	2000\$/MMBtu		
	Basis Differential	Winter	Summer
APS-DQE	0.27	0.16	(0.25)
CAR	0.47	0.22	(0.38)
CNV	0.38	0.10	(0.11)
DNSNY	0.65	0.22	(0.39)
ENTERGY	0.09	0.14	(0.20)
ERCOT	(0.06)	0.12	(0.15)
FRCC	0.38	0.08	(0.08)
LILCO	0.62	0.24	(0.41)
MAPP	(0.11)	0.17	(0.27)
MECS	0.21	0.14	(0.20)
NEPOOL	0.45	0.22	(0.36)
PACNW	(0.31)	0.25	(0.45)
PJME	0.40	0.20	(0.34)
PJMS	0.40	0.19	(0.32)
PJMW	0.45	0.20	(0.34)
S. ECAR	0.27	0.16	(0.25)
S. MAIN	0.17	0.16	(0.25)
SOU	0.09	0.13	(0.19)
SPP	(0.12)	0.15	(0.21)
TVA	0.11	0.14	(0.20)
UPSNY	0.25	0.18	(0.30)
VI EP	0.47	0.22	(0.38)
WSCR	(0.27)	0.25	(0.45)
WUMS	0.16	0.16	(0.24)

Oil

EIA (AEO2003) Oil Prices Delivered to New England (Year 2000 \$/MMBtu)

- To remain consistent with the natural gas price trajectory, the Reference Case will include EIA's AEO 2003 assumptions for delivered oil prices to New England.

Year	Residual Fuel Price (2000\$/MMBtu)	Distillate Fuel Price (2000\$/MMBtu)
2005	3.14	4.98
2010	3.26	5.05
2015	3.39	5.40
2020	3.52	5.72
2025	3.65	5.88

Variable O&M

Non-Fuel Variable O&M by Capacity Type

- Segmental variable O&M captures changing costs that result from start-up and cycling. Non-fuel segmental variable O&M is an inverse function of a unit's capacity factor, with low capacity factors implying higher variable O&M and high capacity factors implying lower variable O&M.
- Base load units that cycle very little have variable O&M rates at the low end of the range shown.

Capacity Type	Variable O&M (2000US\$/MWh)
Scrubbed Coal	1.75 – 2.50
Unscrubbed Coal	0.74 – 1.50
Oil/Gas Steam	0.75 – 3.00
Combined Cycle	1.90 – 6.80
Combustion Turbine	2.06 – 8.45
Nuclear	1.05
Hydro and Pumped Storage	-

New Power Plants

Financing for Capital Projects

- ICF considers the capital charge rate as the levelized rate of return on an investment. The components of this rate are not based on traditional utility financing, but rather focus more on how marginal merchant projects (or components of projects designed for spot sales) will be financed in a deregulated industry.
- ICF's Reference Case has financing costs varying across different projects. Differences in book life and debt-equity ratios lead to different capital charge rates and discount rates across projects. In all cases, however, a nominal after-tax rate of return on equity of 13.0 percent and an interest rate on debt of 8.0 percent is incorporated.

Reference Case Financial Assumptions for New Capacity and Pollution Controls

	Combustion Turbines	Renewables	Combined Cycles	Coal	Retrofits
Input:					
Debt Life (years)	15	15	20	20	15
Book Life (years)	30	20	30	30	20
After Tax Equity Rate (%)	13	13	13	13	13
Equity Ratio (%)	75	30	55	45	30
Debt Rate (%)	8	8	8	8	8
Debt Ratio (%)	25	70	45	55	70
Income Tax Rate (%)	41.2	41.2	41.2	41.2	41.2
Other Taxes/Insurance (%)	2.1	2.1	2.1	2.1	2.1
Inflation (%)	2.25	2.25	2.25	2.25	2.25
Output:					
Levelized Real Fixed Capital Charge Rate (%)	15.3	10.5	13.3	12.9	12.9

Nuclear Technologies

Reference Case Will Assume That Nuclear Plants Relicense at End of 40 Year Operating Period

- Almost half of the 4 GW of nuclear capacity in NEPOOL will face potential license expiration prior to 2020 as they reach their 40-yr license period.
- The Stakeholders have decided to assume that these units will relicense and continue to operate throughout the study period.
- All nuclear plants will be allowed to economically retire if they are unable to cover their going-forward fixed costs. This decision is made within the model through an evaluation of the potential future revenues stream for each plant.

Nuclear Units Will Have Option to Uprate

- Existing units will have the option to invest in a capacity uprate as determined on an economic basis by the model.
- The table on the following page shows the uprate potential and associated cost for each of the nuclear units in New England and neighboring states.
 - Uprate potential and type by unit is taken from “U.S. Commercial Nuclear Power Industry Assessment for Department of Energy Energy Information Agency”, October 2001.
 - Uprate cost by type assumed to be the middle of the range published in Power magazine article, July/August 2001.

Nuclear Units Will Have Option to Uprate cont.

Unit	State	Capacity Summer Dependable (MW)	License Expiration Date	Uprate Potential (MW)	Uprate Option Type	Uprate Option Cost (\$/kW)
Millstone: 3	CT	1,120	Nov. 2025	57	Stretch	\$268
Millstone: 2	CT	923	Jul. 2015	43	Stretch	\$268
Pilgrim: 1	MA	669	Jun. 2012	60	Stretch	\$268
Seabrook: 1	NH	1,155	Oct. 2026	57	Stretch	\$268
Vermont Yankee: 1	VT	496	Mar. 2012	110	Extended	\$575
Calvert Cliffs: 1	MD	850	Jul. 2034	42	Stretch	\$268
Calvert Cliffs: 2	MD	850	Aug. 2036	42	Stretch	\$268
Hope Creek	NJ	1031	Apr. 2026	100	Extended	\$575
Oyster Creek	NJ	650	Apr. 2009	32	Stretch	\$268
Salem: 1	NJ	1106	Aug. 2016	55	Stretch	\$268
Salem: 2	NJ	1106	Apr. 2020	55	Stretch	\$268
Fitzpatrick	NY	825	Oct. 2014	25	Stretch	\$268
GINNA	NY	490	Sept. 2009	25	Stretch	\$268
Indian Point: 2	NY	975	Sept. 2013	97	Extended	\$575
Indian Point: 3	NY	980	Dec. 2015	50	Stretch	\$268
Nine Mile Point: 1	NY	609	Aug. 2009	60	Extended	\$575
Nine Mile Point: 2	NY	1148	Oct. 2026	57	Stretch	\$268
Beaver Valley: 1	PA	810	Jan. 2016	60	Extended	\$575
Beaver Valley: 2	PA	833	Mar. 2027	62	Extended	\$575
Peach Bottom: 2	PA	1160	Aug. 2033	116	Extended	\$575
Peach Bottom: 3	PA	1160	Jul. 2034	116	Extended	\$575
Susquehanna: 1	PA	1100	Jul. 2022	110	Extended	\$575
Susquehanna: 2	PA	1100	Mar. 2024	110	Extended	\$575
Three Mile Island: 1	PA	875	Apr. 2014	45	Stretch	\$268

Coal and Gas Technologies

Greenfield Power Plant Costs and Performance

- The Reference Case assumes that future power plant costs will decline and efficiency will improve.
- Capital cost assumptions on the following slide are overnight capital costs and do not include interest during construction (IDC), but do include interconnection costs.
- Capital, fixed O&M, and variable O&M cost estimates include the costs of emission controls required to comply with New Source Performance Standards.
- The capital costs are adjusted by region to reflect variations in labor costs and unit capacity adjustments that result from changes in elevation and temperature.

EIA AEO 2003 Technology Costs – Greenfield Power Plant Characteristics for Potential Units (Year 2000 \$)

	Advanced Coal (IGCC)	Combined Cycle	Combustion Turbine
2010			
Heat Rate (Btu/kWh)	7,873	7,056	10,939
Capital (\$/kW)	1,289	515	393
Fixed O&M (\$/kW-yr)	32.9	12.0	10.0
Variable O&M (\$/MWh)	2.0	2.0	4.0
2015			
Heat Rate (Btu/kWh)	7,200	7,000	10,450
Capital (\$/kW)	1,260	509	388
Fixed O&M (\$/kW-yr)	32.9	12.0	10.0
Variable O&M (\$/MWh)	2.0	2.0	4.0
2020			
Heat Rate (Btu/kWh)	7,200	7,000	10,450
Capital (\$/kW)	1,231	503	384
Fixed O&M (\$/kW-yr)	32.9	12.0	10.0
Variable O&M (\$/MWh)	2.0	2.0	4.0

Renewable/Advanced Technologies

Renewable Resources Included in the Analysis

- The Stakeholders have decided to include the following renewable resources in the analysis. The “Qualifying Capacity” entries include only those technologies that will be represented as options in the analysis. Some capacities that do qualify, such as tidal energy, will not be examined within IPM®. These include:
 - Biomass Gasification
 - Fuel Cells
 - Small Hydro (< 5MW)
 - Landfill Gas
 - Wind
 - Solar PV
- The following slides outline the cost and performance and resource availability agreed upon by the Stakeholders for this analysis.

Biomass Gasification

Overview

- The tables on the following slides show the cost and performance and resource potential assumptions to be used in this analysis.
- The Working Group has chosen to adopt cost and performance data from EIA's AEO 2003 for new biomass gasification capacity.
- The Working Group has chosen to use a recent study* commissioned by the Northeast Regional Biomass Program of Coalition of Northeast Governors as the basis for biomass potential and supply curves by resource category in the 11 Northeast states.
 - Incremental 10 percent price adjustments were made to resources in the Agricultural Residues, Forest Residues and Dedicated Crops categories to reflect incremental costs associated with ensuring that the sustainability criteria are met.
 - The 10% categories had no potential resources at the \$1.40/MMBtu step, so the 10% adjustment applies only to the higher \$3.50/MMBtu step.
 - The Primary Mill Wastes and Tree Residue categories will be included as specified in the report.
 - The Secondary Mill Wastes, Paper Sludge, Urban Wood Wastes and Waste Paper resources will not be included.

Biomass Gasification

Cost/Performance

Cost and Performance of New Biomass Gasification Capacity

	2005	2010	2015	2020
Overnight Capital Cost (Yr, 2000 \$/kW)	1,718	1,635	1,547	1,464
Fixed O&M (Yr. 2000 \$/kW/yr.)	44.9	44.9	44.9	44.9
Variable O&M (Yr. 2000 \$/MWh)	2.89	2.89	2.89	2.89
Heat Rate (Btu/kWh)	8,911	8,911	8,911	8,911
Average Capacity Factor (%)	80%	80%	80%	80%

Biomass Gasification

New England, NY and PJM Resource Potential*

Biomass Potential (Cumulative TBtu)

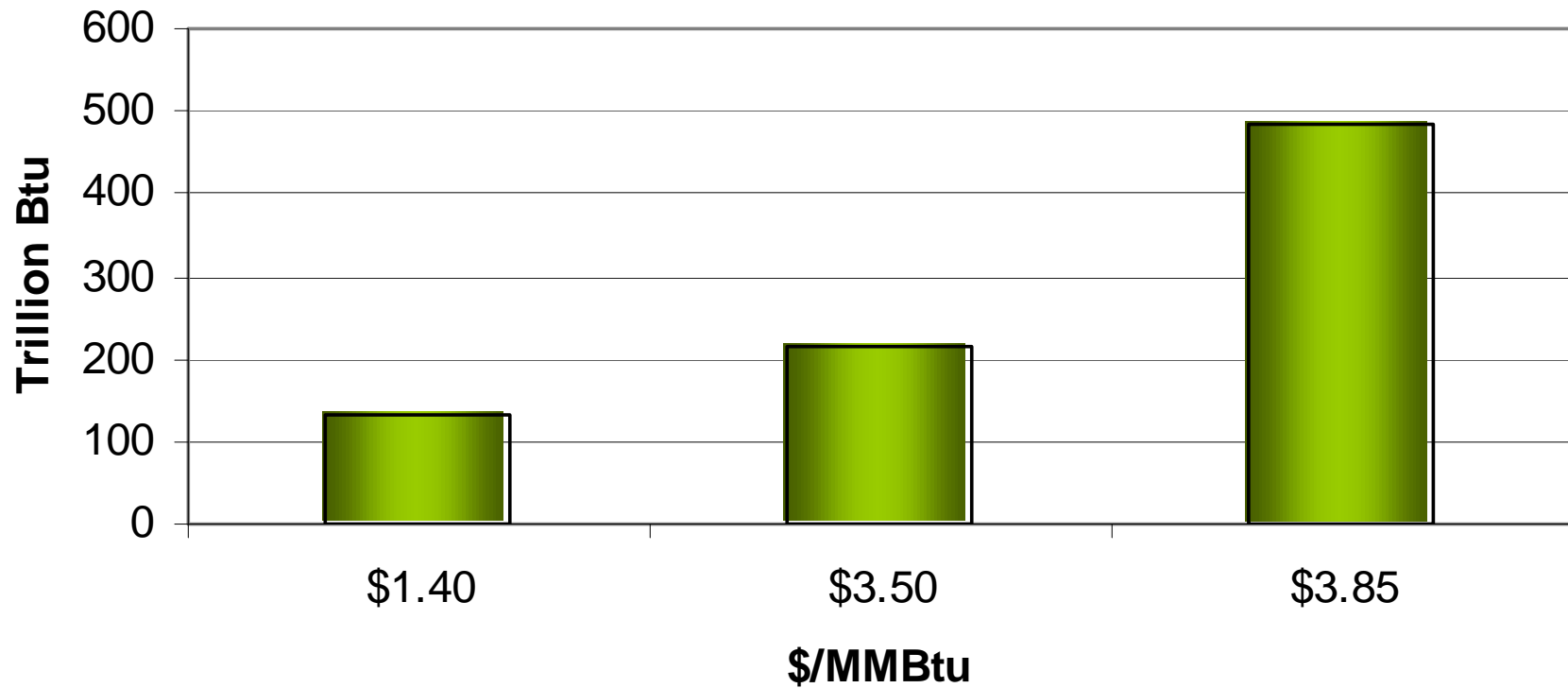

* Resource will be divided by IPM[®] region based on state-specific values provided in Xenergy report.

Fuel Cells

Cost/Performance and Resource Potential

- Given the existence of leading fuel cell companies in Connecticut, the benefits of distributed generation, and the recognition of fuel cells as Class I renewable energy resources, the Stakeholders believe that fuel cells have an important role to play in in-state renewable energy generation.
- The tables below show the cost and performance assumptions to be used in this analysis. These assumptions will serve as the basis for new fuel cell capacity in all regions modeled.
 - Cost and performance data for 2005 based on Connecticut Clean Energy Fund RFP response.
 - Improvement in capital cost equivalent to EIA AEO 2003 average rate of annual improvement for fuel cells. EIA does not project improvement in heat rate or capacity factor, so these values are assumed to remain constant over time.
- The Working Group has chosen to assume a 50 MW cap on fuel cell potential in Connecticut based on a fuel cell farm project currently under development and anticipated fuel cell installments in Connecticut by the CCEF over the next several years. Other regions will face no such limits.

	2005	2010	2015	2020
Overnight Capital Cost (Yr, 2000 \$/kW)	4,500	4,390	4,283	4,179
Fixed O&M (Yr. 2000 \$/kW/yr.)	-	-	-	-
Variable O&M (Yr. 2000 \$/MWh)	-	-	-	-
Heat Rate (Btu/kWh)	7,200	7,200	7,200	7,200
Average Capacity Factor (%)	90%	90%	90%	90%

Hydroelectric Energy

Overview

- Data for the cost and performance and resource potential assumptions for hydroelectric technology was taken from the U.S. Department of Energy's Hydropower Program, operated by the Idaho National Engineering and Environmental Laboratory (INEEL).
 - Cost and performance data was taken from the program's "Estimation of Economic Parameters of U.S. Hydropower Resources" (June 2003) report.
 - Resource potential by state for sites with potential of under 5 MW was taken from the Hydropower Program's Hydropower Evaluation Software (HES) database.

Hydroelectric Energy Resource Potential

- Potential hydropower sites were classified by INEEL as one of three types: sites without any existing structure (“undeveloped”), sites with existing dams but no generator (“without power”, and sites with expansion potential of existing generation sources (“with power”). The Working Group has decided to include only the “with power” and “without power” resources in this analysis because of the difficulty of siting new dams.
- The resource potential reflects a probability-weighted capacity potential based on site-specific probability factors assigned by INEEL that reflect environmental and land-use constraints impacting the likelihood of development.
- The table below shows the probability-weighted resource potential by state for sites with development/expansion potential under 5 MW.

State	With Power	Without Power	Total
CT	0.7	13.6	14.4
DE	0.0	0.0	0.0
MA	2.5	24.0	26.5
MD	0.0	2.3	2.3
ME	10.9	34.1	44.9
NH	0.0	22.5	22.5
NJ	0.0	5.3	5.3
NY	28.3	124.2	152.5
PA	3.6	40.6	44.2
RI	0.0	10.2	10.2
VT	13.5	21.4	34.9
NEPOOL, PJM and NY	59.4	298.3	357.7

Hydroelectric Energy

Cost/Performance

- As estimated in the Hydropower Program study, the development cost to add or expand generating capacity at existing dams is composed of licensing, construction and mitigation (fish and wildlife, recreation, etc.) components.
- The capital costs shown in the table below reflect estimates from the cost formulas derived by the Hydropower Program for 5 MW units of each type (with power and without power).*
 - Operating costs are also shown in the table.
 - Cost functions taken from Tables 3 and 5 of “Estimation of Economic Parameters of U.S. Hydropower Resources” (June 2003).
- The average annual capacity factor was estimated based on annual capacity factor by state weighted by the resource potential in each state.

Values in Year 2000 \$	With Power	Without Power
<i>Licensing (\$/kW)</i>	\$130	\$191
<i>Construction (\$/kW)</i>	\$1,031	\$1,620
<i>Mitigation¹ (\$/kW)</i>	\$847	\$1,125
Total Development Cost (\$/kW)	\$2,007	\$2,937
Fixed O&M Cost (\$/kW-yr)		\$16
Variable O&M ² (\$/MWh)		\$4
Average Annual Capacity Factor (%)		52%

1 “Mitigation” includes provisions for fish and wildlife, recreation, historical and archeological, water quality and fish passage.

2 Assumes capacity factor as shown.

Landfill Gas

Overview

- The following slide shows the cost and performance and resource bound assumptions to be used in this analysis. Both sets of assumptions are based on information from EPA's Landfill Methane Outreach Program (LMOP).
- The resource potential includes under construction and planned projects at landfills that already have an operational project, as well as operational projects that have excess gas, and therefore more potential, but are not actively seeking a project expansion.
- Candidate landfills are identified in the LMOP database by the following criteria:
 - the landfill has at least one million tons of waste-in-place AND is either open or has been closed less than 5 years AND the landfill does not already have an operational or under construction project OR
 - the landfill has a planned project or has been determined to have project potential AND does not already have an operational or under construction project.
- Landfills that don't meet candidate criteria but may still have potential are also included in these counts -- this includes landfills that are flaring LFG that are not candidates and don't have an operational project, under construction projects at landfills that don't already have an operational project, and landfills whose waste-in-place will soon reach one million tons.

Landfill Gas

Cost/Performance and Resource Potential

Cost and Performance of New Capacity

	2005	2010	2015	2020
Overnight Capital Cost (Yr, 2000 \$/kW)	1,243	1,243	1,243	1,243
Fixed O&M (Yr. 2000 \$/kW/yr.)	47	47	47	47
Variable O&M (Yr. 2000 \$/MWh)	15	15	15	15
Heat Rate (Btu/kWh)	10,000	10,000	10,000	10,000
Average Capacity Factor (%)	90%	90%	90%	90%

Potential Capacity

State	Potential (MW)
CT	18.5
MA	23.9
ME	9.0
NH	0.0
RI	0.3
VT	5.1
NY	49.0
NJ	93.0
PA	118.0
Total	316.8

Wind Energy Resource Potential

- The Stakeholders have decided to adopt a newly completed GIS assessment by NREL using up-to-date wind resource data (True Wind Solutions for New England) with new DOE approved exclusion protocols.
- Identified Class 3 and greater resources in the applicable NY, PJM and NEPOOL (CT and MA) RPS regions.

State	0-5 miles from Transmission					5-10 miles from transmission				
	Class 3	Class 4	Class 5	Class 6	Class 7	Class 3	Class 4	Class 5	Class 6	Class 7
Connecticut	0.0	0.0	0.0	0.0	0.0	0.3	0.0	0.0	0.0	0.0
Delaware	187.9	0.0	0.0	0.0	0.0	79.6	3.8	0.0	0.0	0.0
Maine	604.6	174.1	78.7	63.8	59.8	1066.2	348.0	191.5	164.4	128.2
Maryland	544.9	106.1	29.9	5.6	0.0	371.5	10.6	1.1	0.0	0.0
Massachusetts	1203.6	292.8	85.5	23.1	9.1	297.7	105.0	58.7	63.2	0.4
New Hampshire	903.0	379.8	204.7	177.2	109.7	680.1	327.4	175.4	161.5	154.7
New Jersey	50.3	2.6	0.0	0.0	0.0	80.6	2.0	0.0	0.0	0.0
New York	16547.6	1755.3	130.5	0.0	0.0	7555.5	822.1	157.0	0.4	0.2
Pennsylvania	1648.4	388.8	139.9	37.6	0.2	665.4	133.1	50.4	29.1	0.2
Rhode Island	3.6	0.0	0.0	0.0	0.0	71.6	13.4	0.0	0.0	0.0
Vermont	1074.0	402.5	192.4	120.1	28.1	1132.6	464.6	228.7	192.7	65.9
West Virginia	1332.4	428.4	184.1	142.4	58.2	991.5	336.3	153.6	121.5	45.4

State	10-20 miles from transmission					>20 miles from transmission					Total Class 3+	Total Class 4+
	Class 3	Class 4	Class 5	Class 6	Class 7	Class 3	Class 4	Class 5	Class 6	Class 7		
Connecticut	36.2	6.2	0.4	0.3	0.0	0.0	0.0	0.0	0.0	0.0	43	7
Delaware	0.6	0.0	0.0	0.0	0.0	0.0	0.0	0.0	0.0	0.0	272	4
Maine	1378.9	662.0	351.3	323.3	176.5	1553.1	423.9	207.2	154.5	94.5	8205	3602
Maryland	1234.7	31.4	0.0	0.0	0.0	160.8	2.4	0.0	0.0	0.0	2499	187
Massachusetts	520.2	203.6	40.5	8.1	0.0	127.0	165.5	106.2	27.9	0.0	3338	1190
New Hampshire	412.8	217.5	111.6	108.7	68.2	324.2	137.2	54.8	30.4	0.9	4740	2420
New Jersey	167.8	10.2	0.0	0.0	0.0	0.0	0.0	0.0	0.0	0.0	314	15
New York	2014.5	239.8	75.9	0.0	0.0	260.4	54.8	0.0	0.0	0.0	29614	3236
Pennsylvania	108.3	21.3	6.2	2.5	0.0	0.0	0.0	0.0	0.0	0.0	3231	809
Rhode Island	1.1	20.3	3.4	0.0	0.0	0.0	0.0	0.0	0.0	0.0	113	37
Vermont	865.1	403.5	200.8	131.7	36.2	24.8	3.1	0.4	0.0	0.0	5567	2471
West Virginia	350.1	137.6	63.1	75.9	35.0	12.9	6.3	2.2	0.9	0.0	4478	1791

Wind Energy

Technology Improvements

- The Stakeholders decided to merge AEO and NREL technology performance/learning data to recognize the expertise of both organizations in assessing technology improvements over time.

	EIA	"Merge"	NREL
Starting Point			
Percentage of Learning Rate	1%		10%
Installations as Learning Opportunities	Cumulative installations w/in the United States		Cumulative installations throughout the world
Assumption Classification	extremely conservative		nominally conservative ^[1]

- Capacity factors are also assumed to reflect a weighted average, based on the potential resource in each class, of EIA and NREL estimates.

Wind Energy

Cost and Performance

Year	Overnight Capital Cost (Yr. 2000 \$/kW)	Fixed O&M (Yr. 2000 \$/kW)	Variable O&M (Yr. 2000 \$/MWh)	Capacity Factor
2005	\$922	\$16.52	\$0.94	31%
2010	\$913		\$0.85	35%
2015	\$905		\$0.80	36%
2020	\$898		\$0.75	37%

Sources: Values are determined as average of EIA AEO 2003 assumptions and assumptions provided by NREL, weighted by potential resource in class. Cost and performance assumptions shown here will characterize wind units modeled in IPM for all classes.

Wind Energy

Degradation Curves

- A new degradation curve using a similar structure to EIA's was developed for this analysis using the new wind resource assessment developed for the CT Stakeholders by NREL, the work being done in New York State on wind development, and interviews with New England wind developers.
- The available wind resource as screened by NREL is dramatically higher than EIA's old estimates. New York developers indicated in interviews, however, that they do not envision more than 6-7 GW being available for development in New York.
- The Stakeholders chose to follow the expectations of developers in New York for all regions in the Northeast and make 75% of the wind resource identified by NREL relatively expensive (2 times).
- For the remaining 25%, the Stakeholders also chose to follow the expectations of NY developers and create a step function with increasing costs (1.0 to 1.5 times to account for variable interconnection and permitting costs).
- The degradation step curve for all states is presented on the following slide.
 - Within the degradation steps for each region, all wind classes will require the same cost to develop and will be assumed to operate with the same performance characteristics, as provided on the previous slide.

Wind Energy

Wind Resource and Cost Degradation

Potential Resource / Installed Capacity (MW) & Cost Degradation						
		Viewed as Developable in the Near Term				
State	Total Class 3 - 7	Step 1 (7%) @ 1.0 x Cost	Step 2 (4%) @ 1.1 x Cost	Step 3 (4%) @ 1.25 x Cost	Step 4 (10%) @ 1.5 x Cost	Step 5 (75%) @ 2.0 x Cost
Connecticut	43	3	2	2	4	33
Rhode Island	113	8	5	5	11	85
Delaware	272	19	11	11	27	204
New Jersey	314	22	13	13	31	235
Maryland	2,499	175	100	100	250	1,874
Pennsylvania	3,231	226	129	129	323	2,424
Massachusetts	3,338	234	134	134	334	2,504
West Virginia	4,478	313	179	179	448	3,358
New Hampshire	4,740	332	190	190	474	3,555
Vermont	5,567	390	223	223	557	4,175
Maine	8,205	574	328	328	820	6,153
New York	29,614	2,073	1,185	1,185	2,961	22,211
Total	62,414	4,369	2,497	2,497	6,241	46,811

Wind Energy

Production Tax Credit

- Currently, the Federal Production Tax Credit (PTC) is valued at roughly \$18/MWh (2003\$) and is available to new wind projects that are installed and operational by the end of 2003. Eligible projects can receive the tax credit for up to 10 years. Although the PTC is set to expire after 2003, various environmental groups and members of the wind industry are pushing for an extension beyond 2003 to further support wind development in a competitive market.
- ICF assumes that a PTC for new wind units is continually renewed through 2020. This effectively reduces the levelized cost of generation for new wind plants built by the model.
- The effective subsidy provided by the PTC is the \$18/MWh rate for 10 years levelized over the assumed 20-year lifetime of a wind project.

Solar Photovoltaic Cost/Performance

- The table below shows the cost and performance assumptions to be used in this analysis.
 - Cost and performance data based on EIA's AEO 2003.

Cost and Performance of New Capacity

	2005	2010	2015	2020
Overnight Capital Cost (Yr, 2000 \$/kW)	2,733	2,462	2,346	2,270
Fixed O&M (Yr. 2000 \$/kW/yr.)	10	10	10	10
Variable O&M (Yr. 2000 \$/MWh)	-	-	-	-
Heat Rate (Btu/kWh)	-	-	-	-
Average Capacity Factor (%)	30%	30%	30%	30%

**CHP Capacity and Planned Capacity
Additions for NEPOOL**

New England CHP Units

- IPM® includes only the CHP capacity that contributes electric generation to the grid. Therefore, the capacity values presented here may be lower than the listed capacities of the units.

Unit Name	State	Capacity (MW)
AGAWAM A	MA	7
BELLINGHAM (MA) B	MA	300
HARVARD UNIV (MATEP)	MA	53
LOWELL (MA) 1	MA	27
LOWELL (MA) B	MA	77
LYNN B	MA	43
MASSPOWER	MA	240
PITTSFIELD COGEN	MA	165
SOMERSET A	ME	43
STRATTON BIOMASS 1	ME	40
WESTBROOK COGEN	ME	62
OCEAN STATE	RI	500

Recent and Firmly Planned Capacity Additions, NEPOOL

Unit	Capacity Type	OnLine Date	Capacity Summer Dependable
AES Londonerry	CC	1/1/2002	678
Agawam Project	CC	6/1/2000	267
ANP Bellingham	CC	1/1/2002	576
Blackstone Project	CC	7/1/2001	552
Bridgeport Project	CC	6/1/2000	465
Bucksport	CC	12/1/2000	169
Fore River	CC	6/1/2003	700
Kendall Power Project	CC	12/18/2002	172
Lake Road, CT: 1	CC	11/1/2001	270
Lake Road, CT: 2	CC	7/1/2001	270
Lake Road, CT: 3	CC	5/1/2002	270
Maine Independence Station Project	CC	5/1/2000	494
Milford, CT	CC	1/1/2000	490

Data for recent and firmly planned capacity additions are from the ISO NE Capacity, Energy, Loads and Transmission (CELT) Report, http://www.iso-ne.com/Historical_Data/CELT_Report/2003_CELT_Report/

Recent and Firmly Planned Capacity Additions, NEPOOL cont.

Unit	Capacity Type	OnLine Date	Capacity Summer Dependable
Millennium Power Project	CC	4/1/2001	331
MYSTIC: 8	CC	4/14/2003	707
MYSTIC: 9	CC	4/14/2003	707
Newington (ConEd)	CC	9/18/2002	522
RI Hope Energy	CC	11/15/2002	500
Rumford	CC	10/30/2000	267
Tiverton (Calpine)	CC	8/18/2000	251
Westbrook	CC	1/1/2001	520
Androscoggin, ME	Cogen	4/1/2000	124
Wallingford	CT	1/15/2002	211
West Springfield, CT	CT	6/7/2002	80

Recent and Firmly Planned Capacity Additions, NEPOOL Capacity Summary

	2000	2001	2002	2003	Total (2000-2003)
CC	2,403	1,943	2,718	2,114	9,178
Cogen	124	0	0	0	124
CT	0	0	291	0	291
Total	2,527	1,943	3,009	2,114	9,593

ICF New Build Emission Profiles

- Integrated Gasification Combined Cycle
 - NO_x: SCR with an emission rate of 0.02 lb/MMBtu
 - SO₂: Emissions rate of zero
- Combined Cycle
 - NO_x: SCR with an emission rate of 0.02 lb/MMBtu (~6 PPM)
 - SO₂: Emissions rate of zero
- Combustion Turbine
 - NO_x: Combustion controls with an emission rate of 0.06 lb/MMBtu (~17 PPM)
 - SO₂: Emissions rate of zero

Emissions Control

Pollution Control Options Based on EPA Assumptions

- Cost and performance assumptions for pollution controls for SO₂, NO_x and mercury will be taken from the US EPA. These include the following control options:
- SO₂ – Wet Flue Gas Desulfurization (FGD), Lime-Spray Drying and Magnesium Enhanced Lime Scrubbers
- NO_x – Selective Catalytic Reduction (SCR) , Selective Non-Catalytic Reduction (SNCR)
- Hg – Activated Carbon Injection (ACI)
- Please refer to EPA “Documentation of EPA Modeling Applications (V.2.1) Using the Integrated Planning Model”, March 2002. The report is also available at <http://www.epa.gov/airmarkets/epa-ipm/#documentation>.